

Efficient Non-parametric Estimation of Multiple Embeddings per Word in Vector Space

Arvind Neelakantan*, Jeevan Shankar*, Alexandre Passos, Andrew McCallum

Department of Computer Science
University of Massachusetts, Amherst
Amherst, MA, 01003

{arvind, jshankar, apassos, mccallum}@cs.umass.edu

Abstract

There is rising interest in vector-space word embeddings and their use in NLP, especially given recent methods for their fast estimation at very large scale. Nearly all this work, however, assumes a single vector per word type—ignoring polysemy and thus jeopardizing their usefulness for downstream tasks. We present an extension to the Skip-gram model that efficiently learns multiple embeddings per word type. It differs from recent related work by jointly performing word sense discrimination and embedding learning, by non-parametrically estimating the number of senses per word type, and by its efficiency and scalability. We present new state-of-the-art results in the word similarity in context task and demonstrate its scalability by training with one machine on a corpus of nearly 1 billion tokens in less than 6 hours.

1 Introduction

Representing words by dense, real-valued vector embeddings, also commonly called “distributed representations,” helps address the curse of dimensionality and improve generalization because they can place near each other words having similar semantic and syntactic roles. This has been shown dramatically in state-of-the-art results on language modeling (Bengio et al, 2003; Mnih and Hinton, 2007) as well as improvements in other natural language processing tasks (Collobert and Weston, 2008; Turian et al, 2010). Substantial benefit arises when embeddings can be trained on large volumes of data. Hence the recent considerable interest in the CBOW and Skip-gram models

of Mikolov et al (2013a); Mikolov et al (2013b)—relatively simple log-linear models that can be trained to produce high-quality word embeddings on the entirety of English Wikipedia text in less than half a day on one machine.

There is rising enthusiasm for applying these models to improve accuracy in natural language processing, much like Brown clusters (Brown et al, 1992) have become common input features for many tasks, such as named entity extraction (Miller et al, 2004; Ratinov and Roth, 2009) and parsing (Koo et al, 2008; Täckström et al, 2012). In comparison to Brown clusters, the vector embeddings have the advantages of substantially better scalability in their training, and intriguing potential for their continuous and multi-dimensional interrelations. In fact, Passos et al (2014) present new state-of-the-art results in CoNLL 2003 named entity extraction by directly inputting continuous vector embeddings obtained by a version of Skip-gram that injects supervision with lexicons. Similarly Bansal et al (2014) show results in dependency parsing using Skip-gram embeddings. They have also recently been applied to machine translation (Zou et al, 2013; Mikolov et al, 2013c).

A notable deficiency in this prior work is that each word type (*e.g.* the word string plant) has only one vector representation—polysemy and homonymy are ignored. This results in the word plant having an embedding that is approximately the average of its different contextual semantics relating to biology, placement, manufacturing and power generation. In moderately high-dimensional spaces a vector can be relatively “close” to multiple regions at a time, but this does not negate the unfortunate influence of the triangle inequality² here: words that are not synonyms but are synonymous with different senses of the same word will be pulled together. For example, pollen and refinery will be inappropriately pulled to a dis-

*The first two authors contributed equally to this paper.

²For distance d , $d(a, c) \leq d(a, b) + d(b, c)$.

tance not more than the sum of the distances plant–pollen and plant–refinery. Fitting the constraints of legitimate continuous gradations of semantics are challenge enough without the additional encumbrance of these illegitimate triangle inequalities.

Discovering embeddings for multiple senses per word type is the focus of work by Reisinger and Mooney (2010a) and Huang et al (2012). They both pre-cluster the contexts of a word type’s tokens into discriminated senses, use the clusters to re-label the corpus’ tokens according to sense, and then learn embeddings for these re-labeled words. The second paper improves upon the first by employing an earlier pass of non-discriminated embedding learning to obtain vectors used to represent the contexts. Note that by pre-clustering, these methods lose the opportunity to jointly learn the sense-discriminated vectors and the clustering. Other weaknesses include their fixed number of sense per word type, and the computational expense of the two-step process—the Huang et al (2012) method took one week of computation to learn multiple embeddings for a 6,000 subset of the 100,000 vocabulary on a corpus containing close to billion tokens.³

This paper presents a new method for learning vector-space embeddings for multiple senses per word type, designed to provide several advantages over previous approaches. (1) Sense-discriminated vectors are learned jointly with the assignment of token contexts to senses; thus we can use the emerging sense representation to more accurately perform the clustering. (2) A non-parametric variant of our method automatically discovers a varying number of senses per word type. (3) Efficient online joint training makes it fast and scalable. We refer to our method as *Multiple-sense Skip-gram*, or *MSSG*, and its non-parametric counterpart as *NP-MSSG*.

Our method builds on the Skip-gram model (Mikolov et al, 2013a), but maintains multiple vectors per word type. During online training with a particular token, we use the average of its context words’ vectors to select the token’s sense that is closest, and perform a gradient update on that sense. In the non-parametric version of our method, we build on *facility location* (Meyerson, 2001): a new cluster is created with probability proportional to the distance from the context to the

nearest sense.

We present experimental results demonstrating the benefits of our approach. We show qualitative improvements over single-sense Skip-gram and Huang et al (2012), comparing against word neighbors from our parametric and non-parametric methods. We present quantitative results in three tasks. On both the SCWS and WordSim353 data sets our methods surpass the previous state-of-the-art. The Google Analogy task is not especially well-suited for word-sense evaluation since its lack of context makes selecting the sense difficult; however our method dramatically outperforms Huang et al (2012) on this task. Finally we also demonstrate scalability, learning multiple senses, training on nearly a billion tokens in less than 6 hours—a 27x improvement on Huang et al.

2 Related Work

Much prior work has focused on learning vector representations of words; here we will describe only those most relevant to understanding this paper. Our work is based on neural language models, proposed by Bengio et al (2003), which extend the traditional idea of n -gram language models by replacing the conditional probability table with a neural network, representing each word token by a small vector instead of an indicator variable, and estimating the parameters of the neural network and these vectors jointly. Since the Bengio et al (2003) model is quite expensive to train, much research has focused on optimizing it. Collobert and Weston (2008) replaces the max-likelihood character of the model with a max-margin approach, where the network is encouraged to score the correct n -grams higher than randomly chosen incorrect n -grams. Mnih and Hinton (2007) replaces the global normalization of the Bengio model with a tree-structured probability distribution, and also considers multiple positions for each word in the tree.

More relevantly, Mikolov et al (2013a) and Mikolov et al (2013b) propose extremely computationally efficient log-linear neural language models by removing the hidden layers of the neural networks and training from larger context windows with very aggressive subsampling. The goal of the models in Mikolov et al (2013a) and Mikolov et al (2013b) is not so much obtaining a low-perplexity language model as learning word representations which will be useful in

³Personal communication with authors Eric H. Huang and Richard Socher.

downstream tasks. Neural networks or log-linear models also do not appear to be necessary to learn high-quality word embeddings, as Dhillon and Ungar (2011) estimate word vector representations using Canonical Correlation Analysis (CCA).

Word vector representations or embeddings have been used in various NLP tasks such as named entity recognition (Neelakantan and Collins, 2014; Passos et al, 2014; Turian et al, 2010), dependency parsing (Bansal et al, 2014), chunking (Turian et al, 2010; Dhillon and Ungar, 2011), sentiment analysis (Maas et al, 2011), paraphrase detection (Socher et al, 2011) and learning representations of paragraphs and documents (Le and Mikolov, 2014). The word clusters obtained from Brown clustering (Brown et al, 1992) have similarly been used as features in named entity recognition (Miller et al, 2004; Ratnikov and Roth, 2009) and dependency parsing (Koo et al, 2008), among other tasks.

There is considerably less prior work on learning multiple vector representations for the same word type. Reisinger and Mooney (2010a) introduce a method for constructing multiple sparse, high-dimensional vector representations of words. Huang et al (2012) extends this approach incorporating global document context to learn multiple dense, low-dimensional embeddings by using recursive neural networks. Both the methods perform word sense discrimination as a pre-processing step by clustering contexts for each word type, making training more expensive. While methods such as those described in Dhillon and Ungar (2011) and Reddy et al (2011) use token-specific representations of words as part of the learning algorithm, the final outputs are still one-to-one mappings between word types and word embeddings.

3 Background: Skip-gram model

The Skip-gram model learns word embeddings such that they are useful in predicting the surrounding words in a sentence. In the Skip-gram model, $v(w) \in R^d$ is the vector representation of the word $w \in W$, where W is the words vocabulary and d is the embedding dimensionality.

Given a pair of words (w_t, c) , the probability that the word c is observed in the context of word

w_t is given by,

$$P(D = 1|v(w_t), v(c)) = \frac{1}{1 + e^{-v(w_t)^T v(c)}} \quad (1)$$

The probability of not observing word c in the context of w_t is given by,

$$P(D = 0|v(w_t), v(c)) = 1 - P(D = 1|v(w_t), v(c))$$

Given a training set containing the sequence of word types w_1, w_2, \dots, w_T , the word embeddings are learned by maximizing the following objective function:

$$J(\theta) = \sum_{(w_t, c_t) \in D^+} \sum_{c \in c_t} \log P(D = 1|v(w_t), v(c)) + \sum_{(w_t, c'_t) \in D^-} \sum_{c' \in c'_t} \log P(D = 0|v(w_t), v(c'))$$

where w_t is the t^{th} word in the training set, c_t is the set of observed context words of word w_t and c'_t is the set of randomly sampled, noisy context words for the word w_t . D^+ consists of the set of all observed word-context pairs (w_t, c_t) ($t = 1, 2, \dots, T$). D^- consists of pairs (w_t, c'_t) ($t = 1, 2, \dots, T$) where c'_t is the set of randomly sampled, noisy context words for the word w_t .

For each training word w_t , the set of context words $c_t = \{w_{t-R_t}, \dots, w_{t-1}, w_{t+1}, \dots, w_{t+R_t}\}$ includes R_t words to the left and right of the given word as shown in Figure 1. R_t is the window size considered for the word w_t uniformly randomly sampled from the set $\{1, 2, \dots, N\}$, where N is the maximum context window size.

The set of noisy context words c'_t for the word w_t is constructed by randomly sampling S noisy context words for each word in the context c_t . The noisy context words are randomly sampled from the following distribution,

$$P(w) = \frac{p_{unigram}(w)^{3/4}}{Z} \quad (2)$$

where $p_{unigram}(w)$ is the unigram distribution of the words and Z is the normalization constant.

4 Multi-Sense Skip-gram (MSSG) model

To extend the Skip-gram model to learn multiple embeddings per word we follow previous work (Huang et al, 2012; Reisinger and Mooney, 2010a)

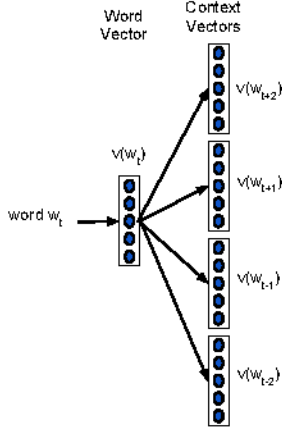

Figure 1: Architecture of the Skip-gram model with window size $R_t = 2$. Context c_t of word w_t consists of $w_{t-1}, w_{t-2}, w_{t+1}, w_{t+2}$.

and let each sense of word have its own embedding, and induce the senses by clustering the embeddings of the context words around each token. The vector representation of the context is the average of its context words' vectors. For every word type, we maintain clusters of its contexts and the sense of a word token is predicted as the cluster that is closest to its context representation. After predicting the sense of a word token, we perform a gradient update on the embedding of that sense. The crucial difference from previous approaches is that word sense discrimination and learning embeddings are performed jointly by predicting the sense of the word using the current parameter estimates.

In the MSSG model, each word $w \in W$ is associated with a global vector $v_g(w)$ and each sense of the word has an embedding (sense vector) $v_s(w, k)$ ($k = 1, 2, \dots, K$) and a context cluster with center $\mu(w, k)$ ($k = 1, 2, \dots, K$). The K sense vectors and the global vectors are of dimension d and K is a hyperparameter.

Consider the word w_t and let $c_t = \{w_{t-R_t}, \dots, w_{t-1}, w_{t+1}, \dots, w_{t+R_t}\}$ be the set of observed context words. The vector representation of the context is defined as the average of the global vector representation of the words in the context. Let $v_{context}(c_t) = \frac{1}{2 \cdot R_t} \sum_{c \in c_t} v_g(c)$ be the vector representation of the context c_t . We use the global vectors of the context words instead of its sense vectors to avoid the computational complexity associated with predicting the sense of the context words. We predict s_t , the sense

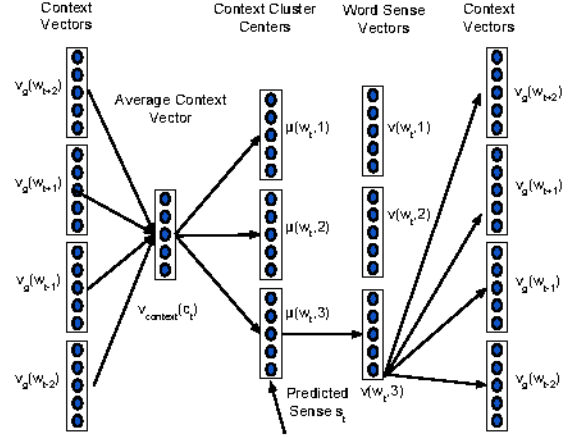

Figure 2: Architecture of Multi-Sense Skip-gram (MSSG) model with window size $R_t = 2$ and $K = 3$. Context c_t of word w_t consists of $w_{t-1}, w_{t-2}, w_{t+1}, w_{t+2}$. The sense is predicted by finding the cluster center of the context that is closest to the average of the context vectors.

of word w_t when observed with context c_t as the context cluster membership of the vector $v_{context}(c_t)$ as shown in Figure 2. More formally,

$$s_t = \arg \max_{k=1,2,\dots,K} \text{sim}(\mu(w_t, k), v_{context}(c_t)) \quad (3)$$

The hard cluster assignment is similar to the k -means algorithm. The cluster center is the average of the vector representations of all the contexts which belong to that cluster. For sim we use cosine similarity in our experiments.

Here, the probability that the word c is observed in the context of word w_t given the sense of the word w_t is,

$$\begin{aligned} P(D = 1 | s_t, v_s(w_t, 1), \dots, v_s(w_t, K), v_g(c)) \\ &= P(D = 1 | v_s(w_t, s_t), v_g(c)) \\ &= \frac{1}{1 + e^{-v_s(w_t, s_t)^T v_g(c)}} \end{aligned}$$

The probability of not observing word c in the context of w_t given the sense of the word w_t is,

$$\begin{aligned} P(D = 0 | s_t, v_s(w_t, 1), \dots, v_s(w_t, K), v_g(c)) \\ &= P(D = 0 | v_s(w_t, s_t), v_g(c)) \\ &= 1 - P(D = 1 | v_s(w_t, s_t), v_g(c)) \end{aligned}$$

Given a training set containing the sequence of word types w_1, w_2, \dots, w_T , the word embeddings are learned by maximizing the following objective

Algorithm 1 Training Algorithm of MSSG model

- 1: Input: $w_1, w_2, \dots, w_T, d, K, N$.
 - 2: Initialize $v_s(w, k)$ and $v_g(w)$, $\forall w \in W, k \in \{1, \dots, K\}$ randomly, $\mu(w, k) \forall w \in W, k \in \{1, \dots, K\}$ to 0.
 - 3: **for** $t = 1, 2, \dots, T$ **do**
 - 4: $R_t \sim \{1, \dots, N\}$
 - 5: $c_t = \{w_{t-R_t}, \dots, w_{t-1}, w_{t+1}, \dots, w_{t+R_t}\}$
 - 6: $v_{context}(c_t) = \frac{1}{2 * R_t} \sum_{c \in c_t} v_g(c)$
 - 7: $s_t = \arg \max_{k=1,2,\dots,K} \{ \text{sim}(\mu(w_t, k), v_{context}(c_t)) \}$
 - 8: Update context cluster center $\mu(w_t, s_t)$ since context c_t is added to context cluster s_t of word w_t .
 - 9: $c'_t = \text{Noisy_Samples}(c_t)$
 - 10: Gradient update on $v_s(w_t, s_t)$, global vectors of words in c_t and c'_t .
 - 11: **end for**
 - 12: Output: $v_s(w, k)$, $v_g(w)$ and context cluster centers $\mu(w, k)$, $\forall w \in W, k \in \{1, \dots, K\}$
-

function:

$$J(\theta) = \sum_{(w_t, c_t) \in D^+} \sum_{c \in c_t} \log P(D = 1 | v_s(w_t, s_t), v_g(c)) + \sum_{(w_t, c'_t) \in D^-} \sum_{c' \in c'_t} \log P(D = 0 | v_s(w_t, s_t), v_g(c'))$$

where w_t is the t^{th} word in the sequence, c_t is the set of observed context words and c'_t is the set of noisy context words for the word w_t . D^+ and D^- are constructed in the same way as in the Skip-gram model.

After predicting the sense of word w_t , we update the embedding of the predicted sense for the word w_t ($v_s(w_t, s_t)$), the global vector of the words in the context and the global vector of the randomly sampled, noisy context words. The context cluster center of cluster s_t for the word w_t ($\mu(w_t, s_t)$) is updated since context c_t is added to the cluster s_t .

5 Non-Parametric MSSG model (NP-MSSG)

The MSSG model learns a fixed number of senses per word type. In this section, we describe a non-parametric version of MSSG, the NP-MSSG model, which learns varying number of senses per word type. Our approach is closely related to

the online non-parametric clustering procedure described in Meyerson (2001). We create a new cluster (sense) for a word type with probability proportional to the distance of its context to the nearest cluster (sense).

Each word $w \in W$ is associated with sense vectors, context clusters and a global vector $v_g(w)$ as in the MSSG model. The number of senses for a word is unknown and is learned during training. Initially, the words do not have sense vectors and context clusters. We create the first sense vector and context cluster for each word on its first occurrence in the training data. After creating the first context cluster for a word, a new context cluster and a sense vector are created online during training when the word is observed with a context where the similarity between the vector representation of the context with every existing cluster center of the word is less than λ , where λ is a hyperparameter of the model.

Consider the word w_t and let $c_t = \{w_{t-R_t}, \dots, w_{t-1}, w_{t+1}, \dots, w_{t+R_t}\}$ be the set of observed context words. The vector representation of the context is defined as the average of the global vector representation of the words in the context. Let $v_{context}(c_t) = \frac{1}{2 * R_t} \sum_{c \in c_t} v_g(c)$ be the vector representation of the context c_t . Let $k(w_t)$ be the number of context clusters or the number of senses currently associated with word w_t . s_t , the sense of word w_t when $k(w_t) > 0$ is given by

$$s_t = \begin{cases} k(w_t) + 1, & \text{if } \max_{k=1,2,\dots,k(w_t)} \{ \text{sim}(\mu(w_t, k), v_{context}(c_t)) \} < \lambda \\ k_{max}, & \text{otherwise} \end{cases} \quad (4)$$

where $\mu(w_t, k)$ is the cluster center of the k^{th} cluster of word w_t and $k_{max} = \arg \max_{k=1,2,\dots,k(w_t)} \text{sim}(\mu(w_t, k), v_{context}(c_t))$.

The cluster center is the average of the vector representations of all the contexts which belong to that cluster. If $s_t = k(w_t) + 1$, a new context cluster and a new sense vector are created for the word w_t .

The NP-MSSG model and the MSSG model described previously differ only in the way word sense discrimination is performed. The objective function and the probabilistic model associated with observing a (word, context) pair given the sense of the word remain the same.

Model	Time (in hours)
Huang et al	168
MSSG 50d	1
MSSG-300d	6
NP-MSSG-50d	1.83
NP-MSSG-300d	5
Skip-gram-50d	0.33
Skip-gram-300d	1.5

Table 1: Training Time Results. First five model reported in the table are capable of learning multiple embeddings for each word and Skip-gram is capable of learning only single embedding for each word.

6 Experiments

To evaluate our algorithms we train embeddings using the same corpus and vocabulary as used in Huang et al (2012), which is the April 2010 snapshot of the Wikipedia corpus (Shaoul and Westbury, 2010). It contains approximately 2 million articles and 990 million tokens. In all our experiments we remove all the words with less than 20 occurrences and use a maximum context window (N) of length 5 (5 words before and after the word occurrence). We fix the number of senses (K) to be 3 for the MSSG model unless otherwise specified. Our hyperparameter values were selected by a small amount of manual exploration on a validation set. In NP-MSSG we set λ to -0.5. The Skip-gram model, MSSG and NP-MSSG models sample one noisy context word (S) for each of the observed context words. We train our models using AdaGrad stochastic gradient decent (Duchi et al, 2011) with initial learning rate set to 0.025. Similarly to Huang et al (2012), we don't use a regularization penalty.

Below we describe qualitative results, displaying the embeddings and the nearest neighbors of each word sense, and quantitative experiments in two benchmark word similarity tasks.

Table 1 shows time to train our models, compared with other models from previous work. All these times are from single-machine implementations running on similar-sized corpora. We see that our model shows significant improvement in the training time over the model in Huang et al (2012), being within well within an order-of-magnitude of the training time for Skip-gram models.

APPLE	
Skip-gram	blackberry, macintosh, acorn, pear, plum
MSSG	pear, honey, pumpkin, potato, nut microsoft, activism, sony, retail, gamestop macintosh, pc, ibm, iigs, chipsets
NP-MSSG	apricot, blackberry, cabbage, blackberries, pear microsoft, ibm, wordperfect, amiga, trs-80
FOX	
Skip-gram	abc, nbc, soapnet, espn, kttv
MSSG	beaver, wolf, moose, otter, swan nbc, espn, cbs, ctv, pbs dexter, myers, sawyer, kelly, griffith
NP-MSSG	rabbit, squirrel, wolf, badger, stoat cbs,abc, nbc, wnyw, abc-tv
NET	
Skip-gram	profit, dividends, pegged, profits, nets
MSSG	snap, sideline, ball, game-trying, scoring negative, offset, constant, hence, potential pre-tax, billion, revenue, annualized, us\$
NP-MSSG	negative, total, transfer, minimizes, loop pre-tax, taxable, per, billion, us\$, income ball, yard, fouled, bounced, 50-yard wnet, tvontorio, cable, tv, tv-5
ROCK	
Skip-gram	glam, indie, punk, band, pop
MSSG	rocks, basalt, boulders, sand, quartzite alternative, progressive, roll, indie, blues-rock rocks, pine, rocky, butte, deer
NP-MSSG	granite, basalt, outcropping, rocks, quartzite alternative, indie, pop/rock, rock/metal, blues-rock
RUN	
Skip-gram	running, ran, runs, afoul, amok
MSSG	running, stretch, ran, pinch-hit, runs operated, running, runs, operate, managed running, runs, operate, drivers, configure
NP-MSSG	two-run, walk-off, runs, three-runs, starts operated, runs, serviced, links, walk running, operating, ran, go, configure re-election, reelection, re-elect, unseat, term-limited helmed, longest-running, mtv, promoted, produced

Table 2: Nearest neighbors of each sense of each word, by cosine similarity, for different algorithms. Note that the different senses closely correspond to intuitions regarding the senses of the given word types.

6.1 Nearest Neighbors

Table 2 shows qualitatively the results of discovering multiple senses by presenting the nearest neighbors associated with various embeddings. The nearest neighbors of a word are computed by comparing the cosine similarity between the embedding for each sense of the word and the context embeddings of all other words in the vocabulary. Note that each of the discovered senses are indeed semantically coherent, and that a reasonable number of senses are created by the non-parametric method. Table 3 shows the nearest neighbors of the word plant for Skip-gram, MSSG, NP-MSSG and Haung's model (Huang et al, 2012).

Skip-gram	plants, flowering, weed, fungus, biomass
MS-SG	plants, tubers, soil, seed, biomass refinery, reactor, coal-fired, factory, smelter asteraceae, fabaceae, arecaceae, lamiaceae, ericaceae
NP-MS-SG	plants, seeds, pollen, fungal, fungus factory, manufacturing, refinery, bottling, steel fabaceae, legume, asteraceae, apiaceae, flowering power, coal-fired, hydro-power, hydroelectric, refinery
Hua-ng et al	insect, capable, food, solanaceous, subsurface robust, belong, pitcher, comprises, eagles food, animal, catching, catch, ecology, fly seafood, equipment, oil, dairy, manufacturer facility, expansion, corporation, camp, co. treatment, skin, mechanism, sugar, drug facility, theater, platform, structure, storage natural, blast, energy, hurl, power matter, physical, certain, expression, agents vine, mute, chalcedony, quandong, excrete

Table 3: Nearest Neighbors of the word *plant* for different models. We see that the discovered senses in both our models are more semantically coherent than Huang et al (2012) and NP-MSSG is able to learn reasonable number of senses.

6.2 Word Similarity

We evaluate our embeddings on two related datasets: the WordSim-353 (Finkelstein et al, 2001) dataset and the Contextual Word Similarities (SCWS) dataset Huang et al (2012).

WordSim-353 is a standard dataset for evaluating word vector representations. It consists of a list of pairs of word types, the similarity of which is rated in an integral scale from 1 to 10. Pairs include both monosemic and polysemic words. These scores to each word pairs are given without any contextual information, which makes them tricky to interpret.

To overcome this issue, Stanford’s Contextual Word Similarities (SCWS) dataset was developed by Huang et al (2012). The dataset consists of 2003 word pairs and their sentential contexts. It consists of 1328 noun-noun pairs, 399 verb-verb pairs, 140 verb-noun, 97 adjective-adjective, 30 noun-adjective, 9 verb-adjective, and 241 same-word pairs. We evaluate and compare our embeddings on both WordSim-353 and SCWS word similarity corpus.

Since it is not trivial to deal with multiple embeddings per word, we consider the following similarity measures between words w and w' given their respective contexts c and c' , where $P(w, c, k)$ is the probability that w takes the k^{th} sense given

the context c , and $d(v_s(w, i), v_s(w', j))$ is the similarity measure between the given embeddings $v_s(w, i)$ and $v_s(w', j)$.

The avgSim metric,

$$\begin{aligned} \text{avgSim}(w, w') &= \frac{1}{K^2} \sum_{i=1}^K \sum_{j=1}^K d(v_s(w, i), v_s(w', j)), \end{aligned}$$

computes the average similarity over all embeddings for each word, ignoring information from the context.

To address this, the avgSimC metric,

$$\begin{aligned} \text{avgSimC}(w, w') &= \sum_{j=1}^K \sum_{i=1}^K P(w, c, i) P(w', c', j) \\ &\quad \times d(v_s(w, i), v_s(w', j)) \end{aligned}$$

weighs the similarity between each pair of senses by how well does each sense fit the context at hand.

The globalSim metric uses each word’s global context vector, ignoring the many senses:

$$\text{globalSim}(w, w') = d(v_g(w), v_g(w')).$$

Finally, localSim metric selects a single sense for each word based independently on its context and computes the similarity by

$$\text{localSim}(w, w') = d(v_s(w, k), v_s(w', k')),$$

where $k = \arg \max_i P(w, c, i)$ and $k' = \arg \max_j P(w', c', j)$ and $P(w, c, i)$ is the probability that w takes the i^{th} sense given context c . The probability of being in a cluster is calculated as the inverse of the cosine distance to the cluster center (Huang et al, 2012).

We report the Spearman correlation between a model’s similarity scores and the human judgments in the datasets.

Table 5 shows the results on WordSim-353 task. C&W refers to the language model by Collobert and Weston (2008) and HLBL model is the method described in Mnih and Hinton (2007). On WordSim-353 task, we see that our model performs significantly better than the previous neural network model for learning multi-representations per word (Huang et al, 2012). Among the methods that learn low-dimensional and dense representations, our model performs slightly better than Skip-gram. Table 4 shows the results for the SCWS task. In this task, when the words are

Model	globalSim	avgSim	avgSimC	localSim
TF-IDF	26.3	-	-	-
Collobort & Weston-50d	57.0	-	-	-
Skip-gram-50d	63.4	-	-	-
Skip-gram-300d	65.2	-	-	-
Pruned TF-IDF	62.5	60.4	60.5	-
Huang et al-50d	58.6	62.8	65.7	26.1
MSSG-50d	62.1	64.2	66.9	49.17
MSSG-300d	65.3	67.2	69.3	57.26
NP-MSSG-50d	62.3	64.0	66.1	50.27
NP-MSSG-300d	65.5	67.3	69.1	59.80

Table 4: Experimental results in the SCWS task. The numbers are Spearman’s correlation $\rho \times 100$ between each model’s similarity judgments and the human judgments, in context. First three models learn only a single embedding per model and hence, avgSim, avgSimC and localSim are not reported for these models, as they’d be identical to globalSim. Both our parametric and non-parametric models outperform the baseline models, and our best model achieves a score of 69.3 in this task. NP-MSSG achieves the best results when globalSim, avgSim and localSim similarity measures are used. The best results according to each metric are in bold face.

Model	$\rho \times 100$
HBLB	33.2
C&W	55.3
Skip-gram-300d	70.4
Huang et al-G	22.8
Huang et al-M	64.2
MSSG 50d-G	60.6
MSSG 50d-M	63.2
MSSG 300d-G	69.2
MSSG 300d-M	70.9
NP-MSSG 50d-G	61.5
NP-MSSG 50d-M	62.4
NP-MSSG 300d-G	69.1
NP-MSSG 300d-M	68.6
Pruned TF-IDF	73.4
ESA	75
Tiered TF-IDF	76.9

Table 5: Results on the WordSim-353 dataset. The table shows the Spearman’s correlation ρ between the model’s similarities and human judgments. G indicates the globalSim similarity measure and M indicates avgSim measure. The best results among models that learn low-dimensional and dense representations are in bold face. Pruned TF-IDF (Reisinger and Mooney, 2010a), ESA (Gabrilovich and Markovitch, 2007) and Tiered TF-IDF (Reisinger and Mooney, 2010b) construct sparse, high-dimensional representations.

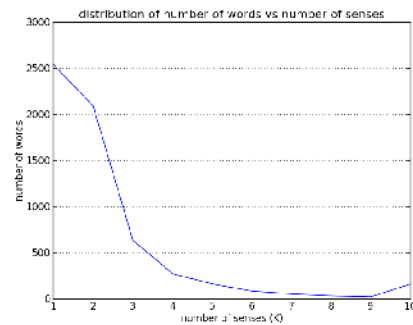
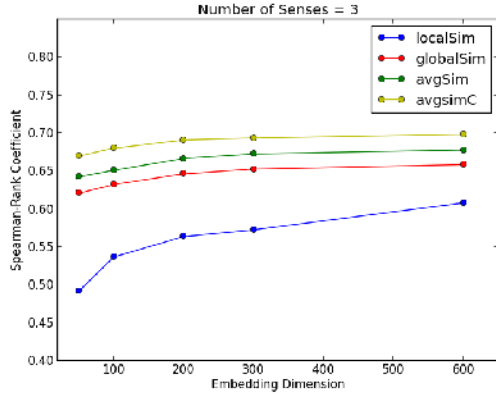

Figure 3: The plot shows the distribution of number of senses learned per word type in NP-MSSG model

given with their context, our model achieves new state-of-the-art results on SCWS as shown in the Table-4. The previous state-of-art model (Huang et al, 2012) on this task achieves 65.7% using the avgSimC measure, while the MSSG model achieves the best score of 69.3% on this task. The results on the other metrics are similar. For a fixed embedding dimension, the model by Huang et al (2012) has more parameters than our model since it uses a hidden layer. The results show that our model performs better than Huang et al (2012) even when both the models use 50 dimensional vectors and the performance of our model improves as we increase the number of dimensions to 300.

We evaluate the models in a word analogy task



(a)

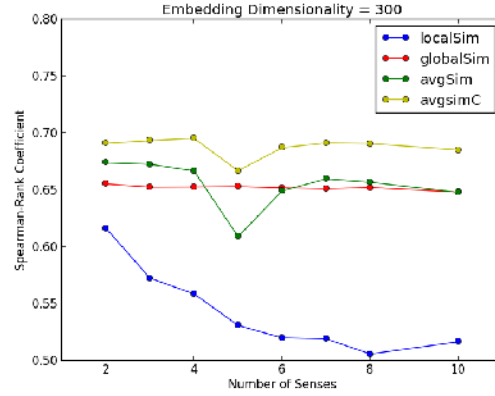

(b)

Figure 4: Figures (a) and (b) show the effect of varying embedding dimensionality and number of senses respectively of the MSSG Model on the SCWS task.

Model	Task	Sim	$\rho \times 100$
Skip-gram	WS-353	globalSim	70.4
MSSG	WS-353	globalSim	68.4
MSSG	WS-353	avgSim	71.2
NP MSSG	WS-353	globalSim	68.3
NP MSSG	WS-353	avgSim	69.66
MSSG	SCWS	localSim	59.3
MSSG	SCWS	globalSim	64.7
MSSG	SCWS	avgSim	67.2
MSSG	SCWS	avgSimC	69.2
NP MSSG	SCWS	localSim	60.11
NP MSSG	SCWS	globalSim	65.3
NP MSSG	SCWS	avgSim	67
NP MSSG	SCWS	avgSimC	68.6

Table 6: Experiment results on WordSim-353 and SCWS Task. Multiple Embeddings are learned for top 30,000 most frequent words in the vocabulary. The embedding dimension size is 300 for all the models for this task. The number of senses for MSSG model is 3.

introduced by Mikolov et al (2013a) where both MSSG and NP-MSSG models achieve 64% accuracy compared to 12% accuracy by Huang et al (2012). Skip-gram which is the state-of-art model for this task achieves 67% accuracy.

Figure 3 shows the distribution of number of senses learned per word type in the NP-MSSG model. We learn the multiple embeddings for the same set of approximately 6000 words that were used in Huang et al (2012) for all our experiments

to ensure fair comparison. These approximately 6000 words were chosen by Huang et al. mainly from the top 30,00 frequent words in the vocabulary. This selection was likely made to avoid the noise of learning multiple senses for infrequent words. However, our method is robust to noise, which can be seen by the good performance of our model that learns multiple embeddings for the top 30,000 most frequent words. We found that even by learning multiple embeddings for the top 30,000 most frequent words in the vocabulary, MSSG model still achieves state-of-art result on SCWS task with an avgSimC score of 69.2 as shown in Table 6.

7 Conclusion

We present an extension to the Skip-gram model that efficiently learns multiple embeddings per word type. The model jointly performs word sense discrimination and embedding learning, and non-parametrically estimates the number of senses per word type. Our method achieves new state-of-the-art results in the word similarity in context task and learns multiple senses, training on close to billion tokens in less than 6 hours. The global vectors, sense vectors and cluster centers of our model and code for learning them are available at <https://people.cs.umass.edu/~arvind/emnlp2014wordvectors>. In future work we plan to use the multiple embeddings per word type in downstream NLP tasks.

Acknowledgments

This work was supported in part by the Center for Intelligent Information Retrieval and in part by DARPA under agreement number FA8750-13-2-0020. The U.S. Government is authorized to reproduce and distribute reprints for Governmental purposes notwithstanding any copyright notation thereon. Any opinions, findings and conclusions or recommendations expressed in this material are those of the authors and do not necessarily reflect those of the sponsor.

References

- Mohit Bansal, Kevin Gimpel, and Karen Livescu. 2014. *Tailoring Continuous Word Representations for Dependency Parsing*. Association for Computational Linguistics (ACL).
- Yoshua Bengio, Réjean Ducharme, Pascal Vincent, and Christian Jauvin. 2003. *A neural probabilistic language model*. Journal of Machine Learning Research (JMLR).
- Peter F. Brown, Peter V. Desouza, Robert L. Mercer, Vincent J. Della Pietra, and Jenifer C. Lai. 1992. *Class-based N-gram models of natural language*. Computational Linguistics.
- Ronan Collobert and Jason Weston. 2008. *A Unified Architecture for Natural Language Processing: Deep Neural Networks with Multitask Learning*. International Conference on Machine Learning (ICML).
- Paramveer S. Dhillon, Dean Foster, and Lyle Ungar. 2011. *Multi-View Learning of Word Embeddings via CCA*. Advances in Neural Information Processing Systems (NIPS).
- John Duchi, Elad Hazan, and Yoram Singer. 2011. *Adaptive sub-gradient methods for online learning and stochastic optimization*. Journal of Machine Learning Research (JMLR).
- Lev Finkelstein, Evgeniy Gabrilovich, Yossi Matias, Ehud Rivlin, Zach Solan, Gadi Wolfman, and Eytan Ruppin. 2001. *Placing search in context: the concept revisited*. International Conference on World Wide Web (WWW).
- Evgeniy Gabrilovich and Shaul Markovitch. 2007. *Computing semantic relatedness using wikipedia-based explicit semantic analysis*. International Joint Conference on Artificial Intelligence (IJCAI).
- Eric H. Huang, Richard Socher, Christopher D. Manning, and Andrew Y. Ng. 2012. *Improving Word Representations via Global Context and Multiple Word Prototypes*. Association of Computational Linguistics (ACL).
- Terry Koo, Xavier Carreras, and Michael Collins. 2008. *Simple Semi-supervised Dependency Parsing*. Association for Computational Linguistics (ACL).
- Quoc V. Le and Tomas Mikolov. 2014. *Distributed Representations of Sentences and Documents*. International Conference on Machine Learning (ICML).
- Andrew L. Maas, Raymond E. Daly, Peter T. Pham, Dan Huang, Andrew Y. Ng, and Christopher Potts. 2011. *Learning Word Vectors for Sentiment Analysis*. Association for Computational Linguistics (ACL).
- Adam Meyerson. 2001. *IEEE Symposium on Foundations of Computer Science*. International Conference on Machine Learning (ICML).
- Tomas Mikolov, Kai Chen, Greg Corrado, and Jeffrey Dean. 2013a. *Efficient Estimation of Word Representations in Vector Space*. Workshop at International Conference on Learning Representations (ICLR).
- Tomas Mikolov, Ilya Sutskever, Kai Chen, Greg Corrado, and Jeffrey Dean. 2013b. *Distributed Representations of Words and Phrases and their Compositionality*. Advances in Neural Information Processing Systems (NIPS).
- Tomas Mikolov, Quoc V. Le, and Ilya Sutskever. 2013c. *Exploiting Similarities among Languages for Machine Translation*. arXiv.
- Scott Miller, Jethran Guinness, and Alex Zamanian. 2004. *Name tagging with word clusters and discriminative training*. North American Chapter of the Association for Computational Linguistics: Human Language Technologies (NAACL-HLT).
- Andriy Mnih and Geoffrey Hinton. 2007. *Three new graphical models for statistical language modelling*. International Conference on Machine Learning (ICML).
- Arvind Neelakantan and Michael Collins. 2014. *Learning Dictionaries for Named Entity Recognition using Minimal Supervision*. European Chapter of the Association for Computational Linguistics (EACL).
- Alexandre Passos, Vineet Kumar, and Andrew McCallum. 2014. *Lexicon Infused Phrase Embeddings for Named Entity Resolution*. Conference on Natural Language Learning (CoNLL).
- Lev Ratinov and Dan Roth. 2009. *Design Challenges and Misconceptions in Named Entity Recognition*. Conference on Natural Language Learning (CoNLL).
- Siva Reddy, Ioannis P. Klapaftis, and Diana McCarthy. 2011. *Dynamic and Static Prototype Vectors for Semantic Composition*. International Joint Conference on Artificial Intelligence (IJCNLP).

- Joseph Reisinger and Raymond J. Mooney. 2010a. *Multi-prototype vector-space models of word meaning*. North American Chapter of the Association for Computational Linguistics: Human Language Technologies (NAACL-HLT)
- Joseph Reisinger and Raymond Mooney. 2010b. *A mixture model with sharing for lexical semantics*. Empirical Methods in Natural Language Processing (EMNLP).
- Cyrus Shaoul and Chris Westbury. 2010. *The Westbury lab wikipedia corpus*.
- Richard Socher, Eric H. Huang, Jeffrey Pennington, Andrew Y. Ng, and Christopher D. Manning. 2011. *Dynamic Pooling and Unfolding Recursive Autoencoders for Paraphrase Detection*. Advances in Neural Information Processing Systems (NIPS).
- Oscar Täckström, Ryan McDonald, and Jakob Uszkoreit. 2012. *Cross-lingual Word Clusters for Direct Transfer of Linguistic Structure*. North American Chapter of the Association for Computational Linguistics: Human Language Technologies.
- Joseph Turian, Lev Ratinov, and Yoshua Bengio. 2010. *Word Representations: A Simple and General Method for Semi-Supervised Learning*. Association for Computational Linguistics (ACL).
- Will Y. Zou, Richard Socher, Daniel Cer, and Christopher D. Manning. 2013. *Bilingual Word Embeddings for Phrase-Based Machine Translation*. Empirical Methods in Natural Language Processing.